

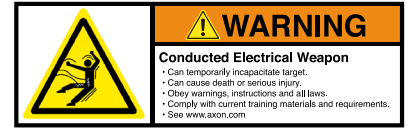

TASER X2 CEW Quick Start Guide

English (U.S./Canada/Australia/U.K.)



Hardware

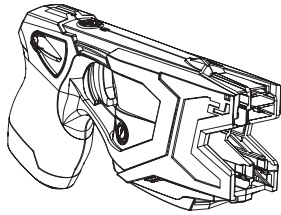

X2 CEW (cartridges sold separately)

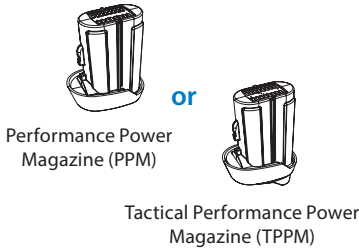

Additional battery packs are available. See www.axon.com for details.

Quick Reference

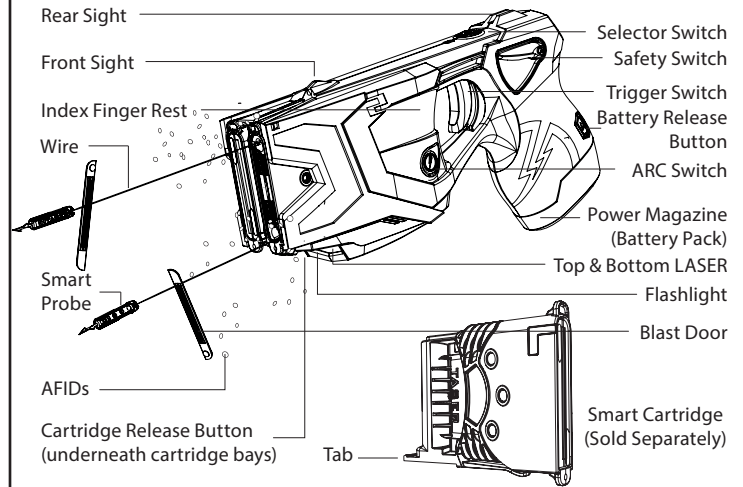

Complete Training First. Significant differences exist between each of the Axon Enterprise, Inc. TASER Conducted Electrical Weapon ("CEW") models. Do not use or attempt to use any CEW model unless you have been trained and certified by a Certified TASER Instructor on that particular model. See www.axon.com, au.axon.com, uk.axon.com for the most current warnings.

Step 1: Place the Safety Switch in the SAFE Position

NOTE: Before using your X2 CEW, confirm with your armorer or other qualified person that the X2 firmware has been updated.

The ambidextrous safety can be operated from either side. Shift the safety switch to the down (SAFE) position.

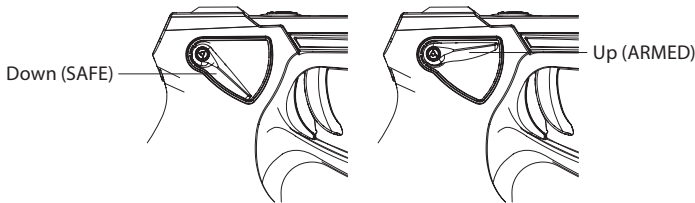

Step 2: Inspect and Install the Battery Pack

- 1 Inspect the battery pack contacts to confirm they are clean and free of damage (Fig.1).
- 2 Install the new battery pack and confirm that it is fully inserted into the X2 CEW (Fig.2).
 - Apply sufficient force to ensure it is fully seated.
 - When the battery pack seats properly, the battery release button should pop out from the recessed position with an audible click.

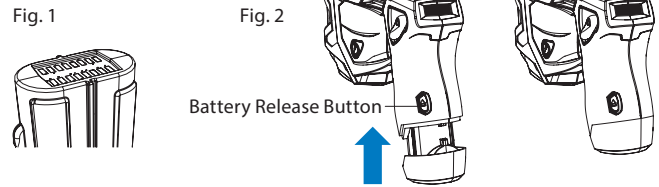
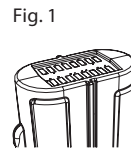

Step 3: Remove the Cartridge Shipping Cover

Smart Cartridges are sold separately. Remove shipping covers before attempting to load a Smart Cartridge into an X2 CEW.

- 1 Hold the cartridge over a table or other close by surface so the cartridge will not fall to the floor if it is dropped.
- 2 Hold the cartridge so the blast doors are facing away from you and others. The blast doors are on the front of the cartridge, behind the solid portion of the cartridge cover with the word REMOVE on it.
- 3 Find the cartridge tab sticking out the rounded side of the shipping cover.
- 4 Push against this tab while pulling the cartridge out. You might consider pushing on the cartridge with your thumbs and holding the cover with your fingers. There should be an audible click when the cover releases the cartridge.
- 5 Pull the cartridge out of the cover.



Step 4:

Load the Smart Cartridges

(Before installing and using a Smart Cartridge, inspect the blast doors for cracks.)

- 1 Point the CEW in a safe direction.
- 2 Ensure the safety switch is in the down (SAFE) position and your finger is not on the trigger or ARC switch.
- 3 Ensure the protective shipping cover is removed from the Smart Cartridge.
- 4 Keeping your hand away from the front of the cartridge, place the cartridge into the cartridge bay until an audible click is heard (Fig.1). Note the position of the tab on the bottom of the cartridge; this side of the cartridge goes in the bottom of the X2 cartridge bay.
- 5 Verify that the cartridge is secure by pulling on the tabs on the lower and upper part of the cartridge (Fig. 2).

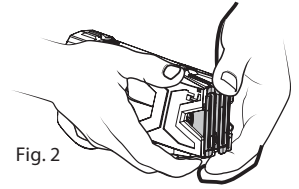
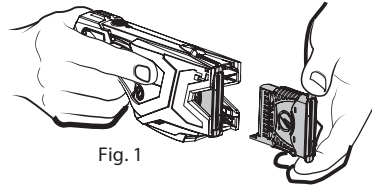

Use the ARC switch, not the trigger, to perform a function test. Pressing the trigger will deploy the cartridge(s). View the electrical arc from the top or side of the CEW. Do not point the CEW at your face or have it near your face.

Step 5:

Function Test

(The function test may be performed with cartridges loaded in the CEW.)

- 1 Point the CEW away from your body and in a safe direction.
- 2 Place the top of the X2 CEW in the palm of your non-dominant hand so you can grip the top rail and your thumb can reach the ARC switch, while the remainder of your non-dominant hand and fingers are away from the front of the CEW.
- 3 Shift the safety switch to the up (ARMED) position. Keep all fingers away from the trigger and keep the CEW pointed in a safe direction. While performing a function test, DO NOT touch the trigger at any time.
- 4 Press and hold the ARC switch for 5 seconds.
- 5 Look at the CID display and verify the following:
 - No critical or major fault icons display.
 - The cartridge information matches the cartridges inserted in the X2 firing bays.
 - CHANGE BATTERY and LO BATT are not displaying on the CID.
 - If any fault icons display, return the unit to your agency's CEW technician for service.
- 6 Shift the safety switch to the down (SAFE) position.

Display Icons

The central information display (CID) provides information about the CEW's battery charge status, cartridge bay status, cartridge type, cycle progress, and other information. When you shift the safety switch to the up (ARMED) position, the CID will light up and display information.

Selected Cartridge — — 35-Foot Cartridge

Operating Mode — — Battery Indicator: 81-100% Remaining

Cartridge Bay Empty	Cartridge Deployed	15' (4.6 m) Cartridge	25' (7.6 m) Cartridge
35' (10.6 m) Cartridge	25' Training Cartridge	Cartridge Bay Error	Cartridge Selected
Semi-Automatic Mode	Manual Mode	Battery*	Battery 21-40% Remaining
Battery Pack Fault	APPM Battery Pack	SPPM Battery Pack	SPPM Mute Mode
TASER CAM HD Recorder	TASER CAM HD Auto-Shutdown Recorder	Major Fault	Critical Fault

* each bar represents a 20% increment of the battery capacity

LO BATT “LO BATT” flashes on the CID when the safety switch is cycled to the up (ARMED) position and the battery capacity is at < 40 percent (with TASER CAM HD recorders) or < 10 percent (with other battery packs).

RECHARGE BATTERY The “RECHARGE BATTERY” icon flashes if the battery pack has rechargeable batteries (e.g., with a TASER CAM HD recorder) and the battery percentage is at 00%. The CEW will not operate until the battery is recharged.

CHANGE BATTERY The “CHANGE BATTERY” icon flashes if the battery pack does not have a rechargeable battery (e.g., a PPM, APPM, SPPM, or TPPM battery pack) and the battery percentage is at 00%. The CEW will not operate until the battery has been replaced.

DO NOT REMOVE BATTERY The “DO NOT REMOVE BATTERY” icon displays if the SPPM battery pack is sending a Signal transmission in safe mode or connected for updates.

1234567890 The CEW will count up from the number 1.

Step 6:

Unload Cartridges

(Point the CEW away from your body.)

- 1 Point the CEW away from your body and in a safe direction.
- 2 Ensure that the safety switch is in the down (SAFE) position.
- 3 Press the cartridge release button with the index finger of your supporting hand.
- 4 Firmly pull the cartridge out of the bay by pulling on the upper tab and lower tab of the cartridge.

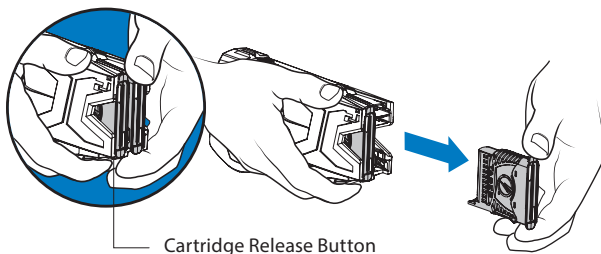

For more information, see the *TASER X2 CEW User Manual*, available at: www.axon.com, au.axon.com, uk.axon.com or call Axon customer service at 1-800-978-2737 to obtain a copy.

▲, Axon, Smart Cartridge, Smart Probe, TASER CAM, X2, X², TASER, and Ⓜ, are trademarks of Axon Enterprise, Inc., some of which are registered in the US and other countries. For more information, visit www.axon.com/legal. All rights reserved. © 2018 Axon Enterprise, Inc. MPC0194 Rev: E

